

**LPMS**  
USA

Low Pressure Molding  
Solutions from Design  
to Production

# KAPPA 700H

Horizontal-injection, Shuttle System  
with External Melt Tank

- ◆ Seven-inch touchscreen, multilanguage operator PLC
- ◆ Three thermal control zones for precise melt control
- ◆ C-frame design with shuttle station
- ◆ Ejection system for easy part removal
- ◆ External high-volume melt tank
- ◆ Equipped with a light curtain, safety door and dual-palm buttons for operator safety

## Dimensions

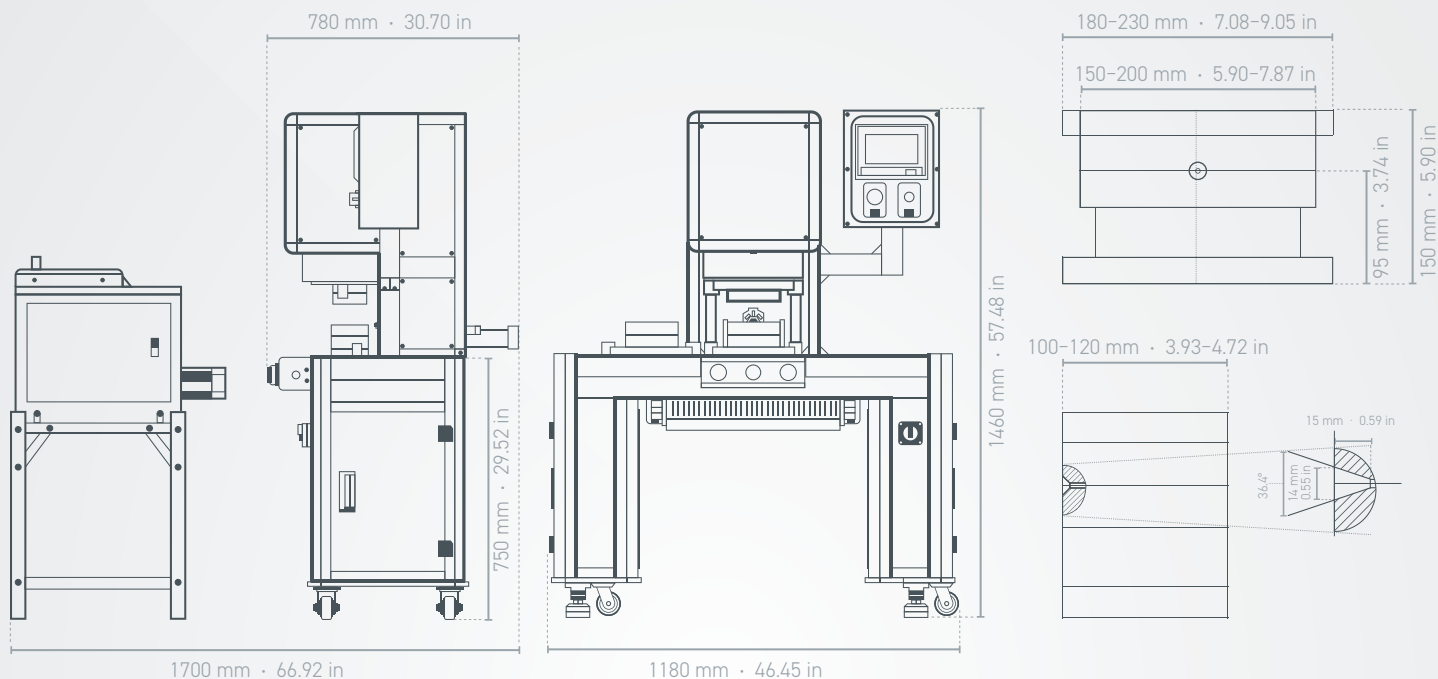

Machine

Mold Set

## Specifications

<b>Machine Size</b>	1180 × 780 × 1460 mm · 46.45 × 30.70 × 57.48 in · 881 lbs
<b>Electricity</b>	200-240 VAC · 1 Phase · 50 or 60 Hz
<b>Air Pressure</b>	0.5-6.0 MPa · 7.3-87.0 psi
<b>Air Volume</b>	3.5 ft <sup>3</sup> /min · 0.1 m <sup>3</sup> /min
<b>Clamping Method</b>	Air cylinder
<b>Clamping Force</b>	2 Ton
<b>Clamping Stroke</b>	150 mm · 5.90 in
<b>Max. Mold Size</b>	305 × 153 × 153 mm · 12.00 × 6.02 × 6.02 in
<b>Nozzle</b>	LPMS-G10
<b>Light Curtain</b>	Standard
<b>Melt Tank Quantity / Volume</b>	One external · 7L
<b>Safety Door</b>	Standard
<b>Temperature Control Zones</b>	3