

LPMS
USA

Low Pressure Molding
Solutions from Design
to Production

BETA 800H

Vertical-injection, single-station system with external melt-tank

- ◆ Vertical-injection system with a single injection gun
- ◆ Seven-inch touchscreen PLC with multi-language capabilities
- ◆ Three thermal zones for precise melt control
- ◆ Equipped with programmable ejection system
- ◆ Equipped with a safety-light curtain and dual palm buttons for operator safety

Dimensions

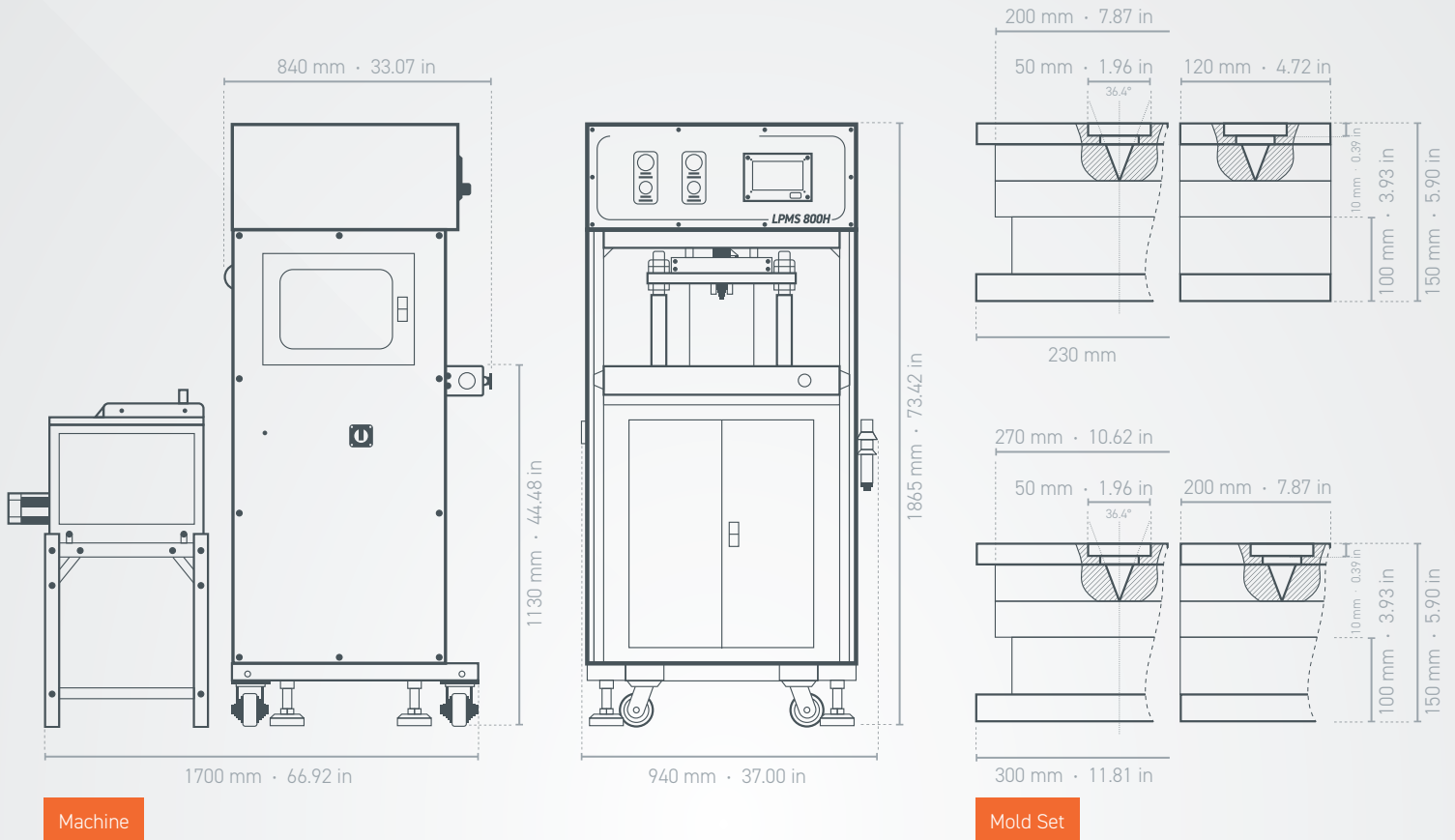

Specifications

Machine Size	940 × 840 × 1865 mm · 37.00 × 33.07 × 73.42 in · 926 lbs
Electricity	200–240 VAC · 1 Phase · 50 or 60 Hz
Air Input	0.2–0.7 MPa · 30–100 psi
Air Required	> 80 psi
Clamping Method	Pneumatic over hydraulic
Clamping Force	5 Ton
Clamping Stroke	150 mm · 5.90 in
Max. Mold Size	300 × 200 × 150 mm · 11.81 × 7.87 × 5.90 in
Nozzle	LPMS-G08
Safety Features	Two-hand actuation · E-stop button · Light curtain · Side safety doors
Melt Tank Quantity / Volume	One external · 7 Liters
Temperature Control Zones	3