

**LPM S**  
USA

Low Pressure Molding  
Solutions from Design  
to Production



## BETA 800HMG

Vertical-injection, dual-gun system  
with two external melt-tanks

- ◆ Vertical-injection, single workstation system
- ◆ 7" touchscreen PLC with multi-language capabilities
- ◆ Five thermal control zones for precise melt control
- ◆ Two independent injection guns
- ◆ Equipped with programmable ejection system
- ◆ Equipped with a light curtain, safety door and dual-palm buttons for operator safety

## Dimensions

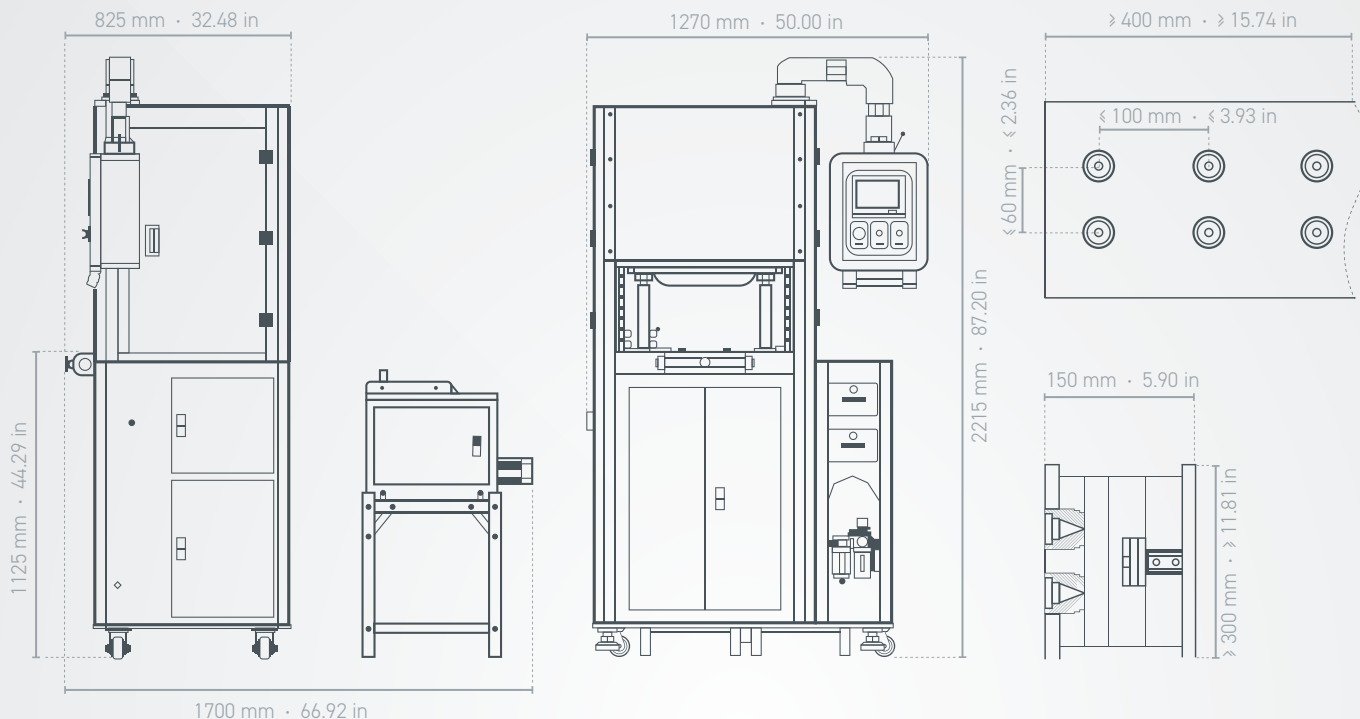

Machine

Mold Set

## Specifications

<b>Machine Size</b>	1245 × 945 × 1982 mm · 49.01 × 37.20 × 78.03 in · 1454 lbs
<b>Electricity</b>	200–240 VAC · 1 Phase · 50 or 60 Hz
<b>Air Input</b>	0.2–0.7 MPa · 30–100 psi
<b>Air Required</b>	> 80 psi
<b>Clamping Method</b>	Pneumatic over hydraulic
<b>Clamping Force</b>	5 Ton
<b>Clamping Stroke</b>	150 mm · 5.90 in
<b>Max. Mold Size</b>	300 × 200 × 150 mm · 11.81 × 7.87 × 5.90 in
<b>Nozzle</b>	LPMS-G02
<b>Safety Features</b>	Two-hand actuation · E-stop button · Light curtain · Side safety doors
<b>Melt Tank Quantity / Volume</b>	Two external · 7 Liters
<b>Temperature Control Zones</b>	6