



**LPMS**  
USA

Low Pressure Molding  
Solutions from Design  
to Production

## BETA 800

Vertical-injection system  
with integrated melt-tank

- ◆ Vertical-injection system with a single injection gun
- ◆ Compact design with integrated melt-tank
- ◆ 5.7" touchscreen PLC with multi-language capabilities
- ◆ Three thermal zones for precise melt control
- ◆ Equipped with programmable ejection system
- ◆ Equipped with a safety-light curtain and dual palm buttons for operator safety

## Dimensions

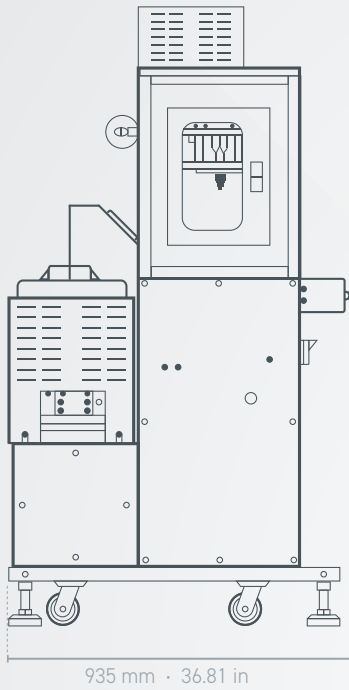

Machine

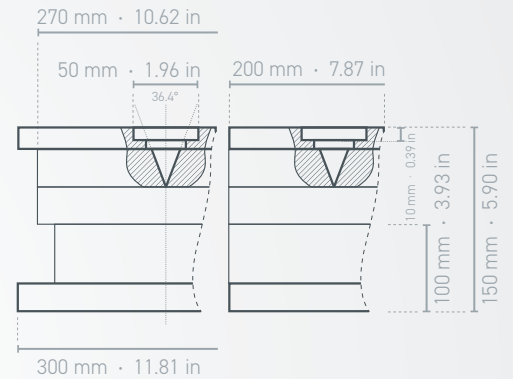
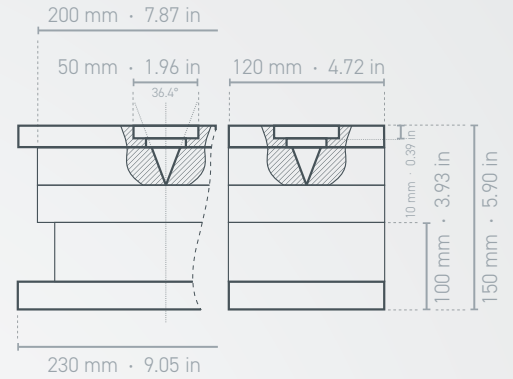
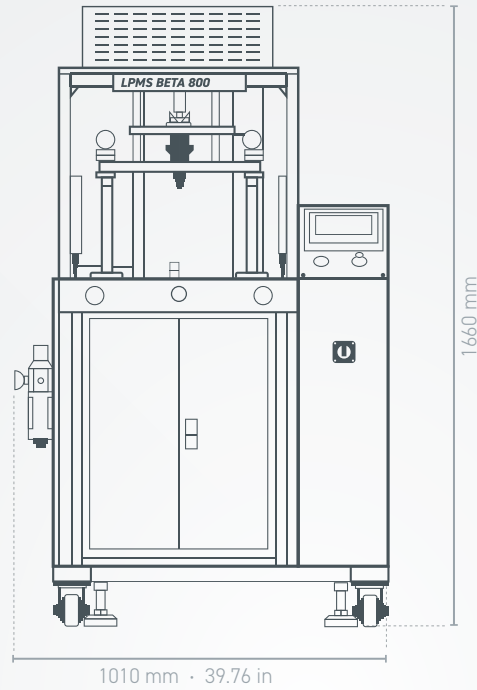

Mold Set

## Specifications

<b>Machine Size</b>	1010 × 935 × 1660 mm · 39.76 × 36.81 × 65.35 in · 771 lbs
<b>Electricity</b>	200–240 VAC · 1 Phase · 50 or 60 Hz
<b>Air Input</b>	0.2–0.7 MPa · 30–100 psi
<b>Air Required</b>	> 80 psi
<b>Clamping Method</b>	Pneumatic
<b>Clamping Force</b>	1.2 Ton
<b>Clamping Stroke</b>	150 mm · 5.90 in
<b>Max. Mold Size</b>	300 × 200 × 150 mm · 11.81 × 7.87 × 5.90 in
<b>Nozzle</b>	LPMS-G08
<b>Safety Features</b>	Two-hand actuation · E-stop button · Light curtain · Side safety doors
<b>Melt Tank Quantity / Volume</b>	One integrated · 5 Liters
<b>Temperature Control Zones</b>	3