



LPMS
USA

Low Pressure Molding
Solutions from Design
to Production

BETA 600

Mobile, horizontal-injection system
with integrated melt-tank

- ◆ Horizontal-injection system with a single injection gun
- ◆ Compact design with integrated melt-tank
- ◆ 5.7" touchscreen with multi-language capabilities
- ◆ Two thermal zones for precise melt control
- ◆ Equipped with programmable ejection system
- ◆ Equipped with a safety-light curtain and side doors for operator safety

Dimensions

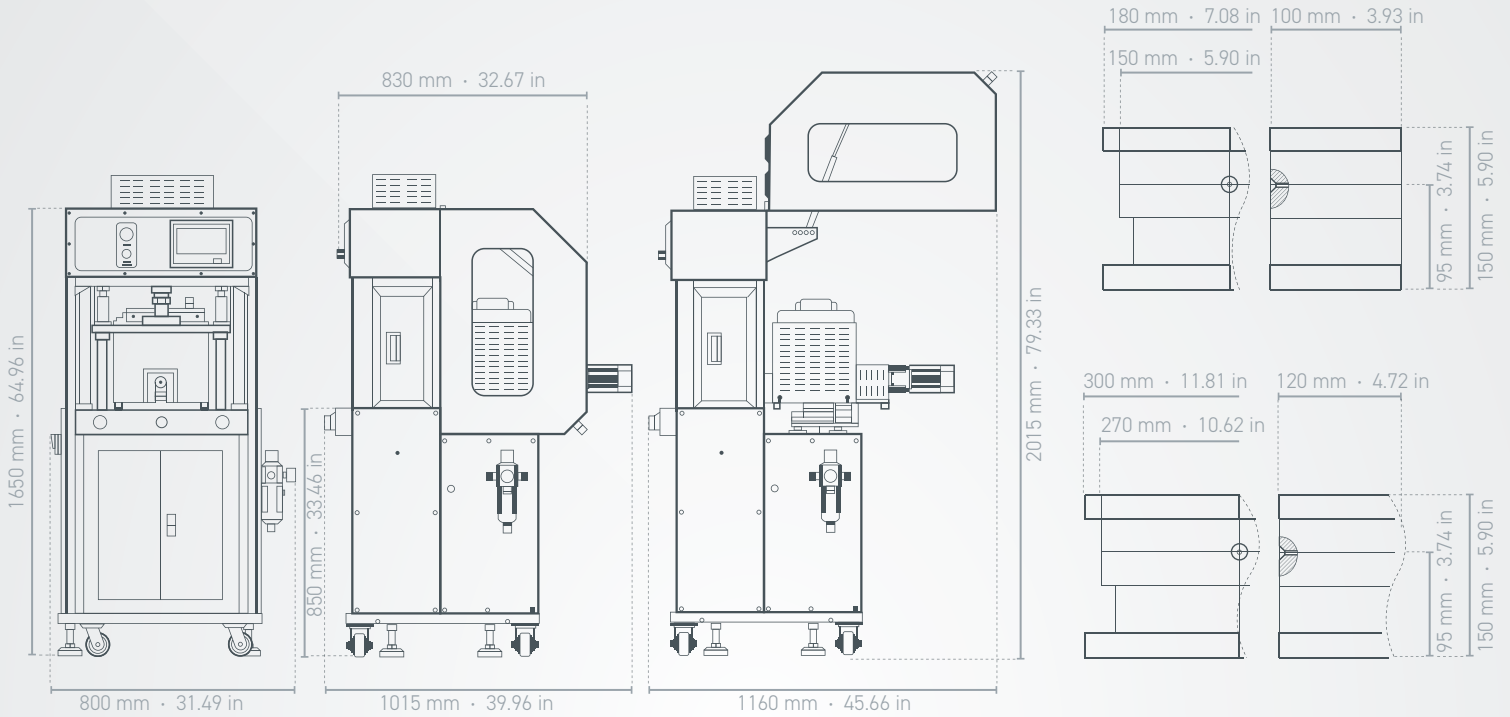

Machine

Mold Set

Specifications

Machine Size	850 × 830 × 1651 mm · 33.46 × 32.68 × 65.0 in · 705 lbs
Electricity	200–240 VAC · 1 Phase · 50 or 60 Hz
Air Input	0.2–0.7 MPa · 30–100 psi
Air Required	> 80 psi
Clamping Method	Pneumatic
Clamping Force	1.2 Ton
Clamping Stroke	150 mm · 5.90 in
Max. Mold Size	250 × 120 × 150 mm · 9.84 × 4.72 × 5.91 in
Nozzle	LPMS-G02
Safety Features	Two-hand actuation · E-stop button · Light curtain · Safety doors
Melt Tank Quantity / Volume	One integrated · 3 Liters
Temperature Control Zones	2