

LPMS
USA

Low Pressure Molding
Solutions from Design
to Production



ALPHA 100

Portable Hotmelt-dispensing Unit
with Quality-monitoring Controls

- ◆ Portable rugged design
- ◆ Pressurized tank integration
- ◆ Precise temperature, injection pressure and timing controls
- ◆ Designed specifically for hotmelt adhesives
- ◆ Lightweight aluminum
- ◆ Easy load design and compact storage

Dimensions

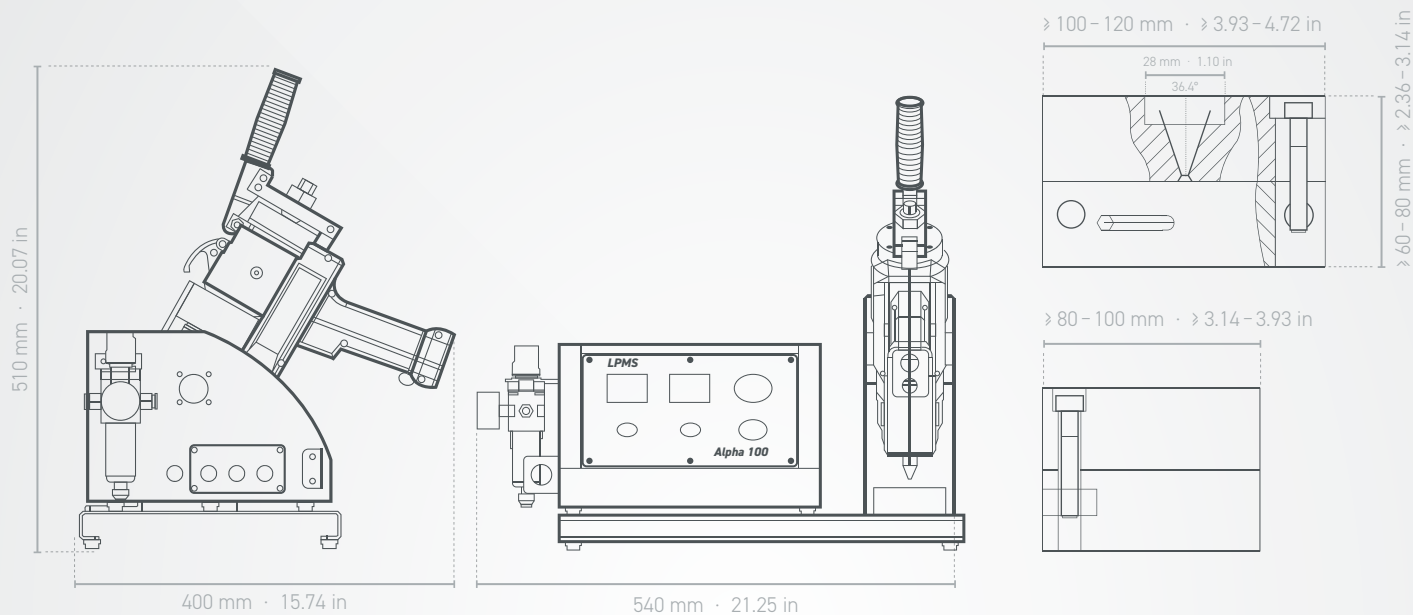

Machine

Mold Set

Specifications

Machine Size	540 × 400 × 510 mm · 21.25 × 15.74 × 20.07 in · 35.0 lbs
Electricity	110-120 VAC · 1 Phase · 50 or 60 Hz
Air Pressure	0.0-0.7 MPa · 14-100 psi
Air Volume	0.7 ft ³ /min · 0.02 m ³ /min
Clamping Method	Optional
Clamping Force	Optional
Clamping Stroke	Optional
Max. Mold Size	120 × 100 × 82mm · 4.72 × 3.93 × 3.22 in
Nozzle	LPMS-G01
Melt Tank Quantity / Volume	One built-in · 0.3L
Temperature Control Zones	1